

UTENSILI PER SBAVATURA



▶ YABARI

UTENSILE COMPENSATO PER SBAVATURA

VELOCITA' DI ROTAZIONE MANDRINO 10.000g/min
SENSO DI ROTAZIONE : ORARIO (M3)
AVANZAMENTO : F2000-F4000 mm/min

Velocità max di rotazione di 10.000min⁻¹

Pinza ER11: gambo lima rotativa fino a 7mm

Gambo W20mm

Meccanismo di compensazione assiale fino a 10mm

E' in grado di compensare differenze del percorso di sbavatura sui 3 assi

Ha un meccanismo di regolazione della forza di sbavatura

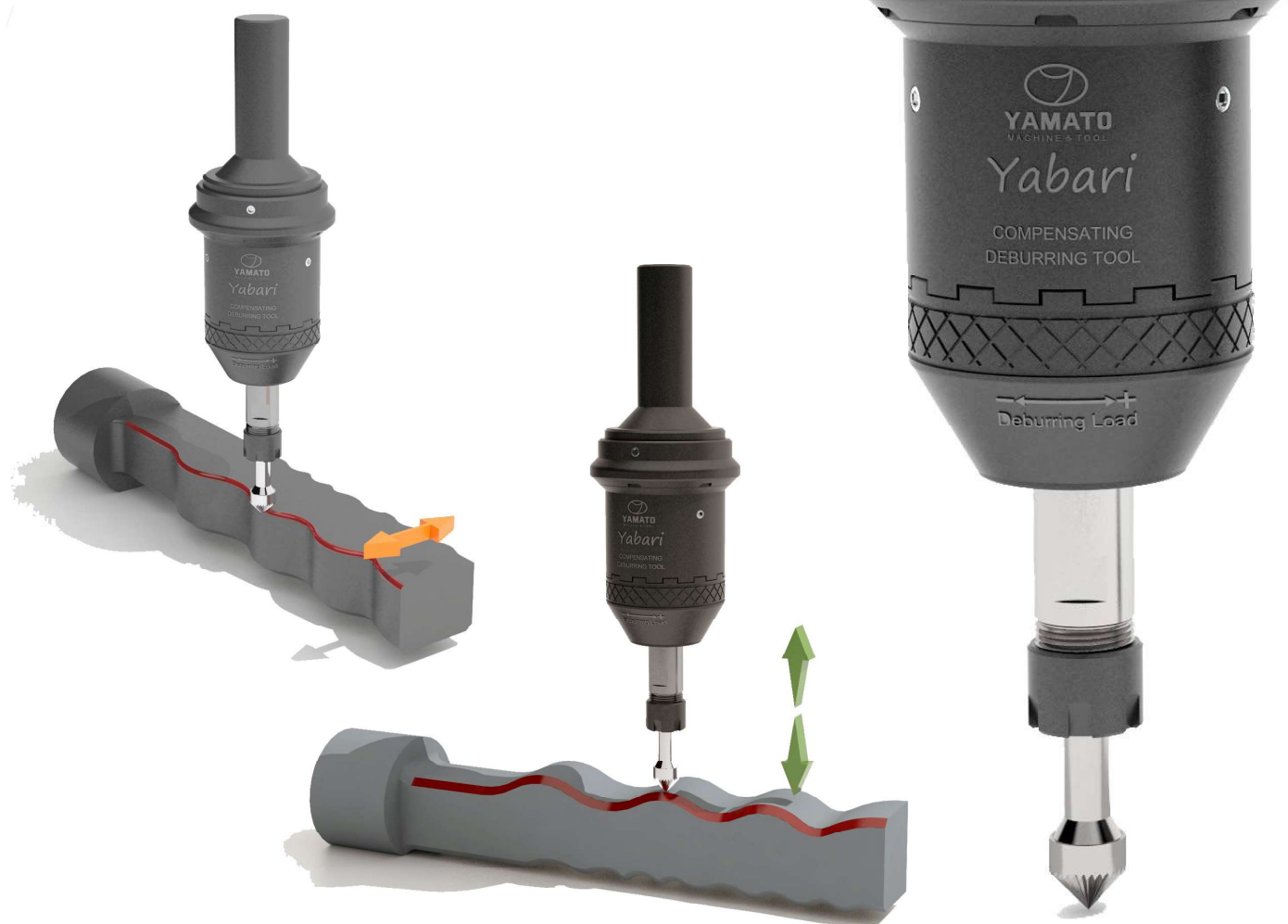

UTENSILI PER SBAVATURA



► YABARI IN SPINTA UTENSILE COMPENSATO PER SBAVATURA

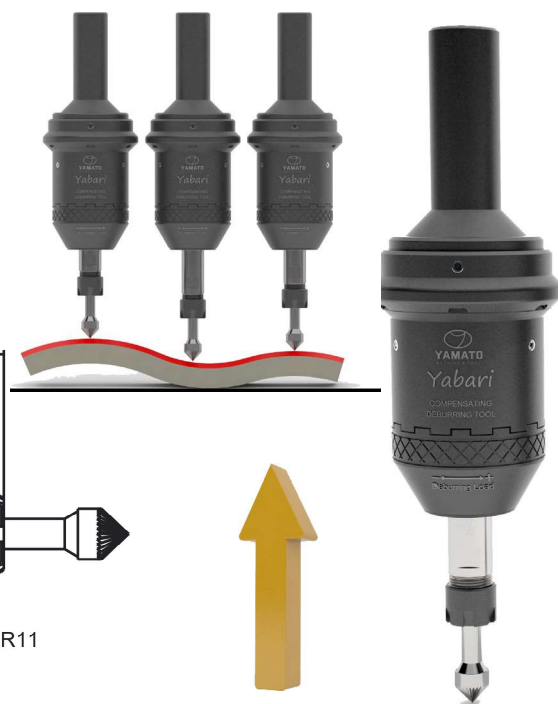
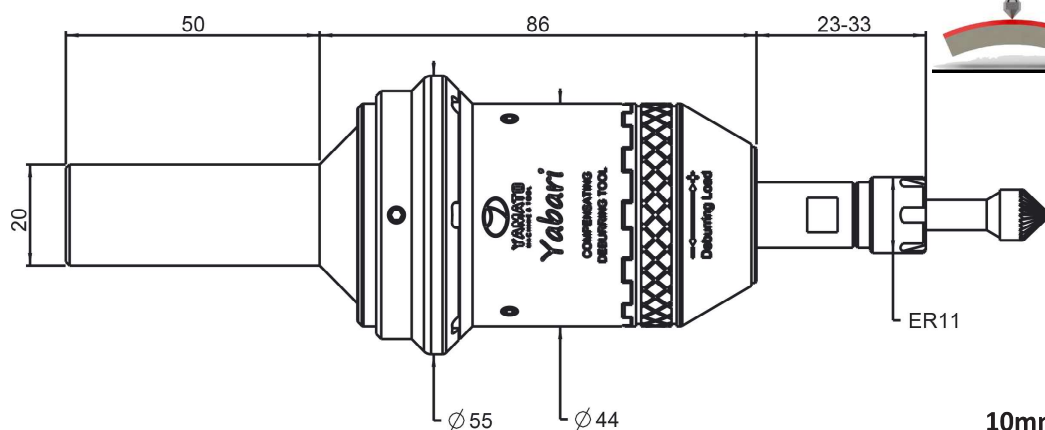

10mm DEFLESSIONE ASSIALE IN SPINTA

► YABARI IN TRAZIONE UTENSILE COMPENSATO PER SBAVATURA

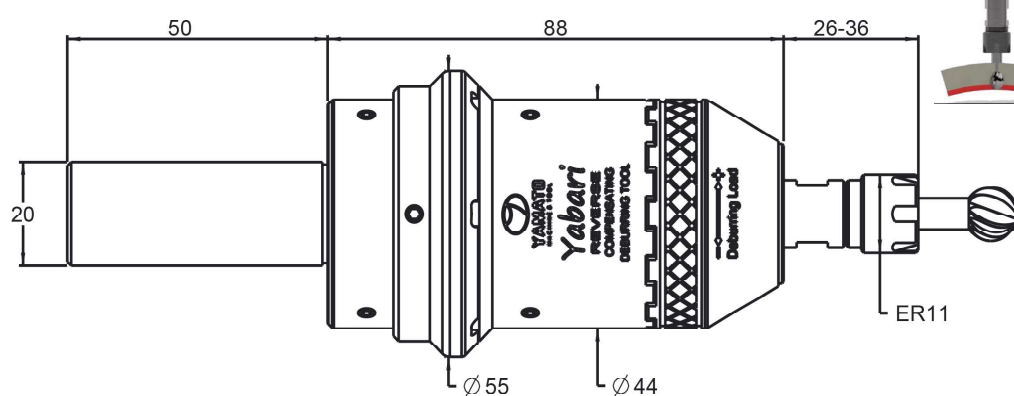

10mm DEFLESSIONE ASSIALE IN TRAZIONE

Accessori inclusi:

Pinza ER11-6mm Ghiera ERM11

Chiave ERM11

