

# DIAMOND BURNISHING TOOLS

## ► YDB-NG



### TOOL HOLDER OPTIONS

- YDB-NG - RH12
- YDB-NG - RH16
- YDB-NG - RH20
- YDB-NG - RH25
- YDB-NG - S12

TOOL HEAD  
ANGULAR POSITION  
BETWEEN  $-105^{\circ}/+105^{\circ}$ .

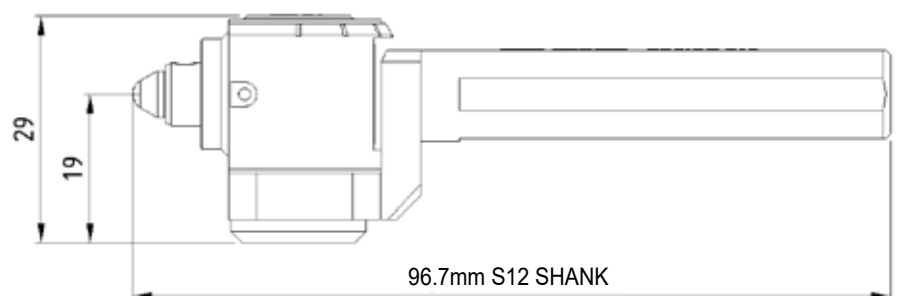
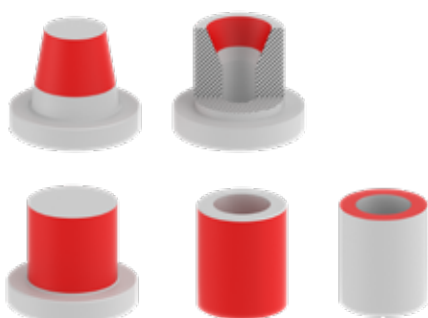
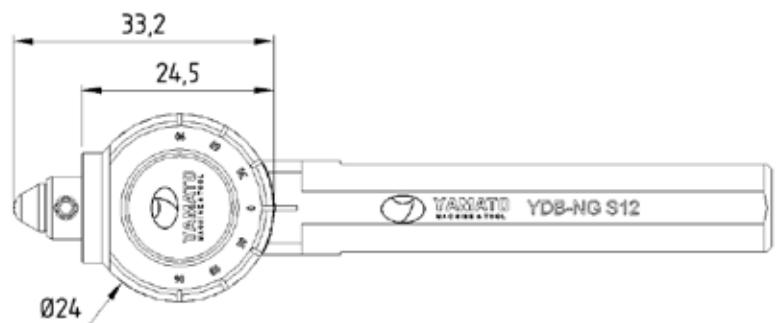

# DIAMOND BURNISHING TOOLS

## ► YDB-NG

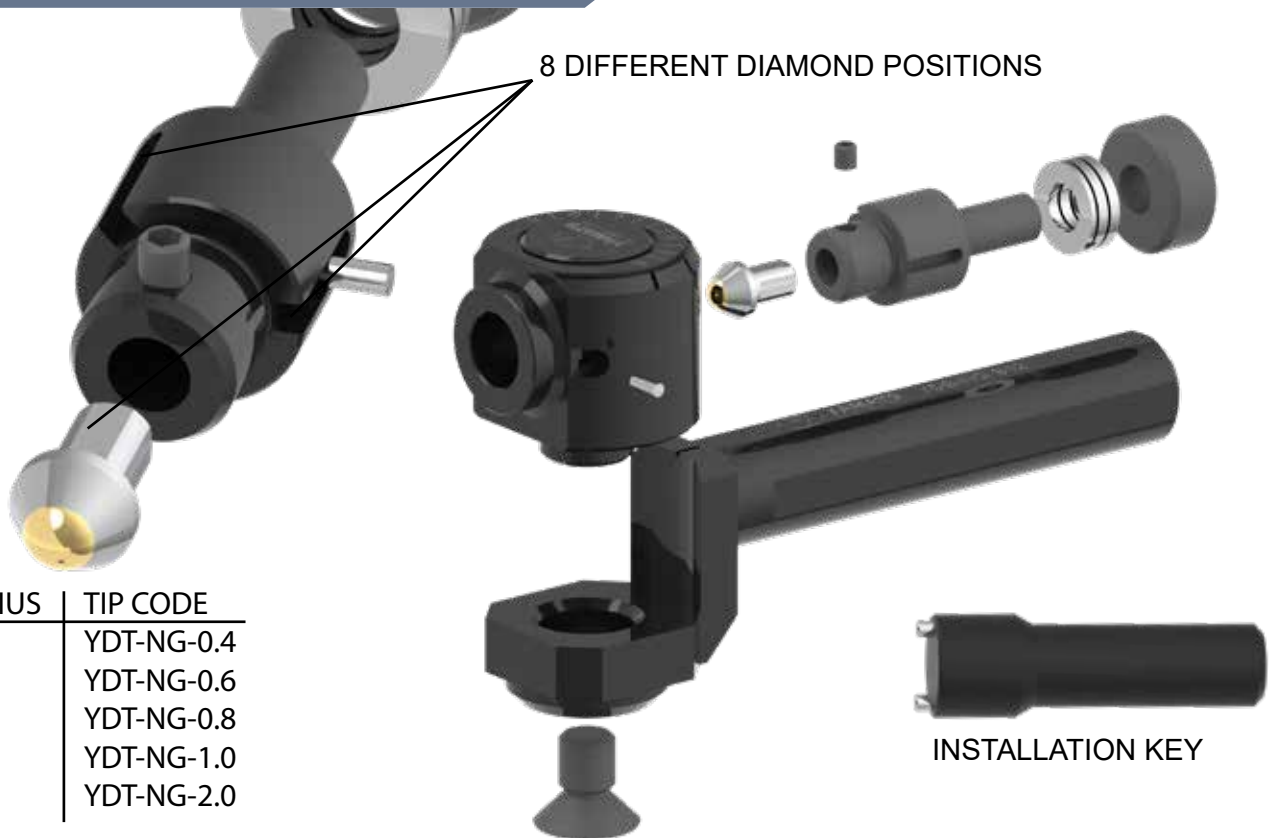

Cylindrical, conical, concave, convex and face geometries can be burnished with the diamond tool.

Burnishing can be done up to a step.

The tool consists of 3 parts: Holder - Head - Diamond Tip. Tool change in the desired configuration can be made by the user.

The tool be delivered with 12x12 - 16x16 - 20x20 - 25x25 - Ø12 holders.

Diamond tips with radius R0.2 - R0.4 - R0.8 - R1.0 - R2.0 can be delivered.

The diamond tip can be connected in 8 different positions by rotating it around itself. Thus, the life of the diamond is up to 8 times longer.

There are cup springs inside the tool head. Spring pressure can be adjusted with the key delivered with the tool.

The tool head can be rotated -105°/+105°.

It can be worked with a max. speed of 200 m/min. - a feed of 0.2 mm/rev.

Coolant must be used.

## YAMATO EU SRL

Via degli Andreani 9  
40037 Sasso Marconi BO  
Italy

info@yamatoroll.eu  
www.yamatoroll.eu

WATCH ME

