

▶ AXIBARI AXIAL DEFLECTION DEBURRING TOOL



AXIAL COMPENSATED DEBURRING TOOL FOR BRUSHING

SPINDLE SPEED 6.000rpm
ROTATION : CW & CCW
FEED : 500-4000 mm/min



- .The holder has a top rated speed of 6.000min
- .The gripping range of the collet is $\varnothing 1$ to $\varnothing 16$ mm for ER25.
- .Built-in mechanism to contract 15mm in the axial direction.

AXIBARI is capable of applying constant pressure of the brush against the surface to work.

AXIBARI allows brushing cycles with less need for corrections on the program to compensate the wear of the brush

AXIBARI brush wear correction steps doesn't need high precision like using the brush rigid direct on the spindle

AXIBARI is suitable also for sealing groove polishing with an abrasive stick in place of the brush where the groove is too little for a brush

- .AXIBARI has built-in load adjustment mechanism.



DEBURRING TOOLS

▶ AXIBARI AXIAL DEFLECTION DEBURRING TOOL

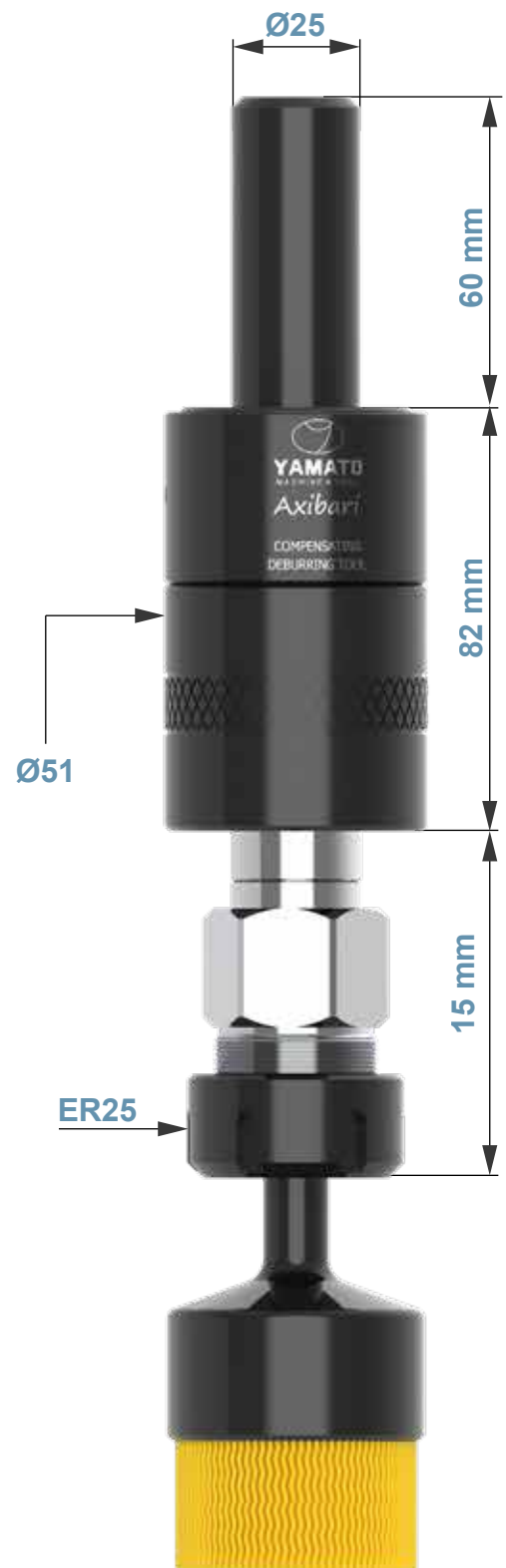

The gripping range of the collet is $\varnothing 1$ to $\varnothing 25$ mm for ER25.

Included Accessories:

ERM25 spanner



ER25 collet 6,10,13,16



ERM25nut



YAMATO Ltd EU Technical Division
TECNIMETAL SRL EU Warehouse
Via degli Andreani 9 - 40037 Sasso Marconi BO - Italy
Phone +39 051735744 - E-mail: info@yamatoroll.eu

www.yamatoroll.eu

WATCH ME