

VSpin 1000 – Smart Spindle



Quality features

- ever crash again due to faulty travel paths or contour deviations
- Monitoring and storage of all relevant data of the deburring process: The component with contour, the burr characteristics, the spindle speed, the deflection, the direction in degrees and much more process data
- Seamless verification for system integrators. Increased safety and precision during system setup and on-going safety and precision in the running process
- Component position and component location can be determined with an accuracy of 0.2mm using the deflection data
- Teaching takes place in a fraction of the time previously required thanks to audio visual feedback
- **Qualität Made in Germany**

Accessories

- | | |
|----------------------|------------|
| – VPort | 600 660 85 |
| – VCable | 600 675 96 |
| – Pressure regulator | 600 585 56 |
| – Adapter UR | 600 588 63 |



Ihr Ansprechpartner

Herr Claus Bay

Technischer Vertrieb

☎ 07159 180 93 -518

☎ 07159 180 93 -100

✉ c.bay@mannesmann-demag.com

VSpin 1000 – Smart Spindle – 600 676 15

Technical data

Type	VSpin 1000
Air supply	Non-lubricated
Free speed	100.000 min ⁻¹
ER collet	3 mm
Power	0,10 kW
Non-lubricated	Yes
Radial deflection	+/- 4°
Exhaust air	to front
Fully variable force of compliance	4-12 N
Direction of rotation	clockwise
Noise level	70 dB(A)
Air consumption	5,3 l/s
Weight	0,82 kg
Connection air supply (hose) ø mm, inside outside	4 6
Accessories supplied	wrench, VCable
Maximum deflection	3,5°
Deflection force	4-20 N
Operating voltage	8,0-13,0 V
Current min. max. value (Note 1)	0,1 0,2 A
Power consumption min max. value	1,1 2,2 Watt
Buzzer volume	max. 85 dB(A)
Data transmission	BLE 4.2/5
Max. power BLE	5 (3,3) dBm (mW)
Operating temperature	+10 bis +85°C
Humidity relative	10-80 %, not dripping
Protection class	IP 40
Tolerance deflection	+/- 0,1°
Tolerance angle	+/- 5°
Cable Vspin (VCable)	6 x 0,14 mm ² LiYCY, 20 meters

All data related to 6,3 bar working pressure.

Subject to technical alterations.

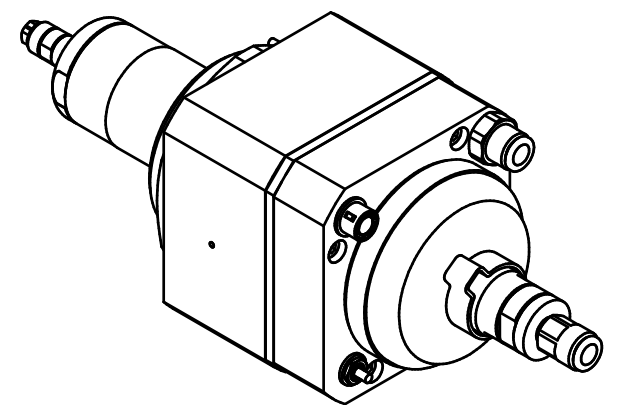
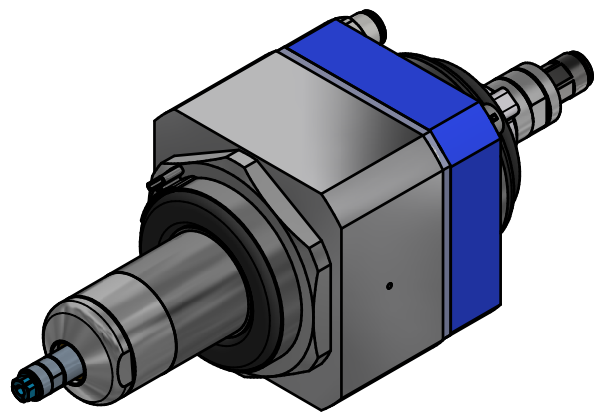
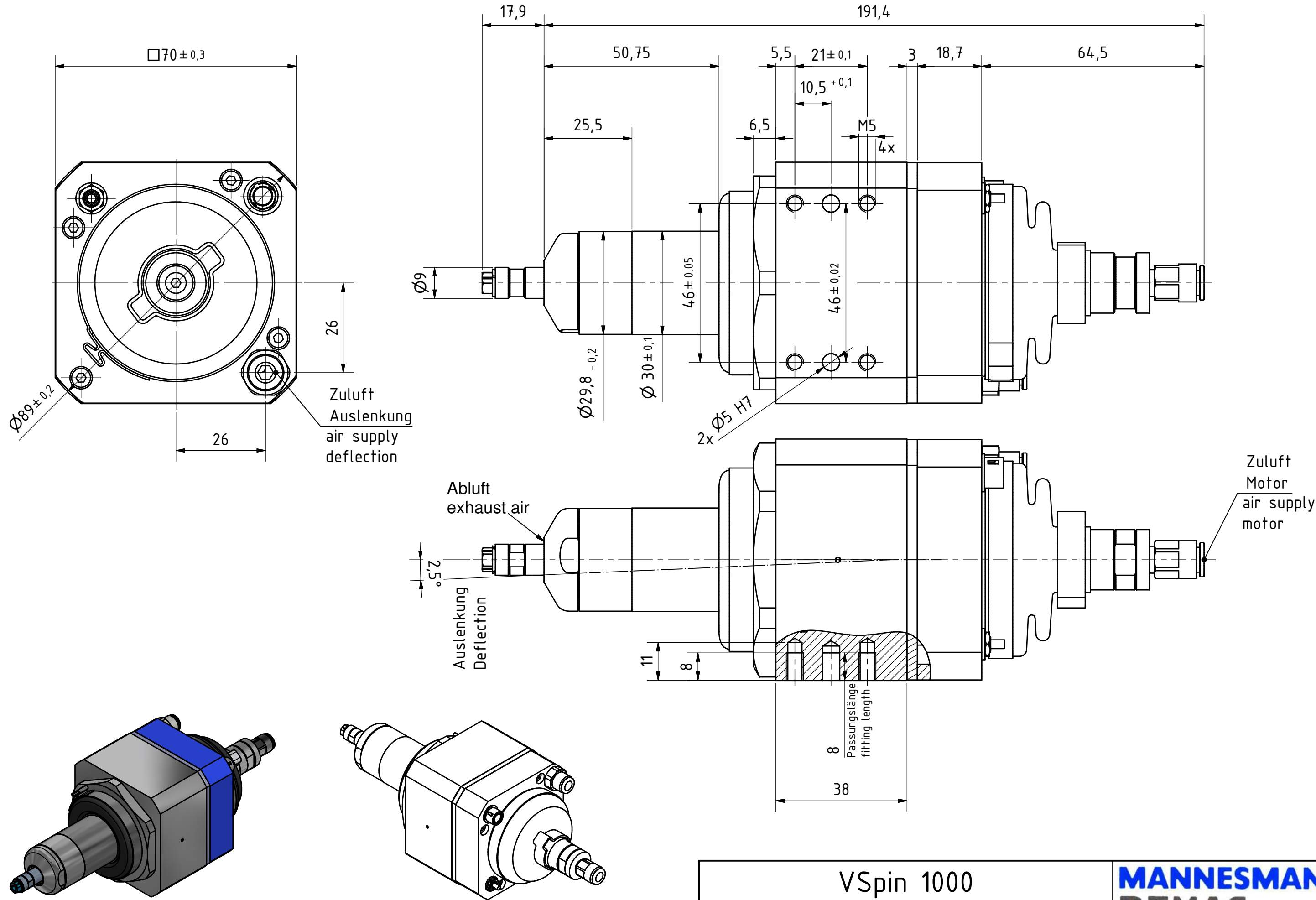

VS pin 1000
60067615

**MANNESMANN
DEMAG**

Änderungsstand: 10.06.2020